

# CENTER CONTROL ABSORBER (w/ REAS)

## COMPONENTS

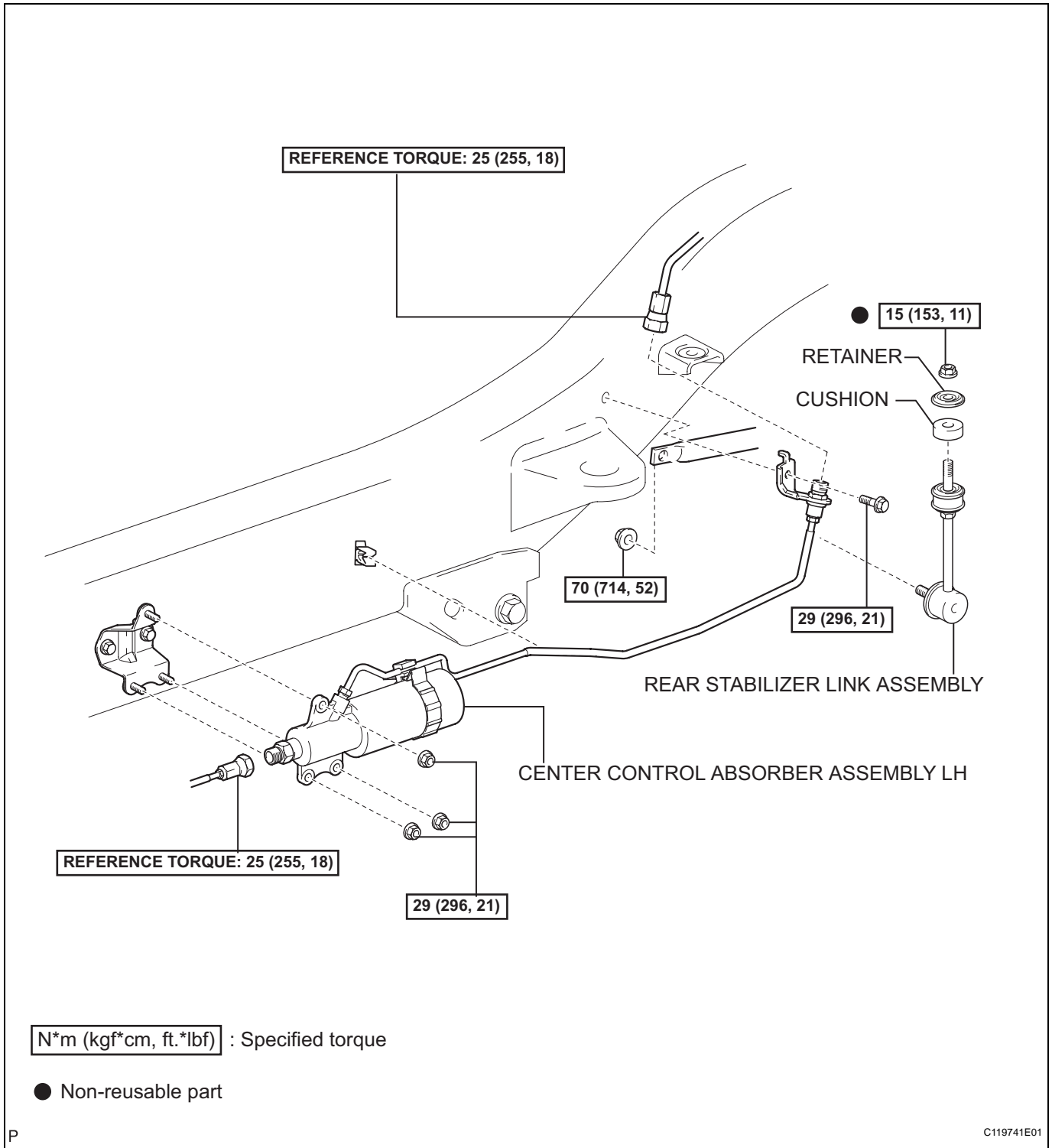

SP

## REMOVAL

### NOTICE:

Be sure to read **PRECAUTIONS** before performing this procedure (See page [SC-1](#)).

1. REMOVE REAR WHEEL
2. REMOVE REAR STABILIZER LINK ASSEMBLY

### HINT:

(See page [SP-53](#))

3. REMOVE CENTER CONTROL ABSORBER ASSEMBLY LH

- (a) Using a spanner to hold the bracket, remove the joint.

### NOTICE:

Check that all four shock absorbers are fully extended to the normal suspension rebound point.

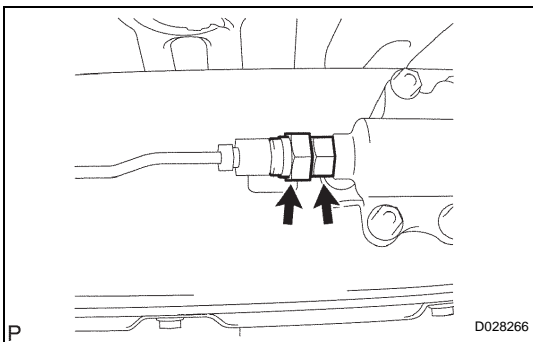
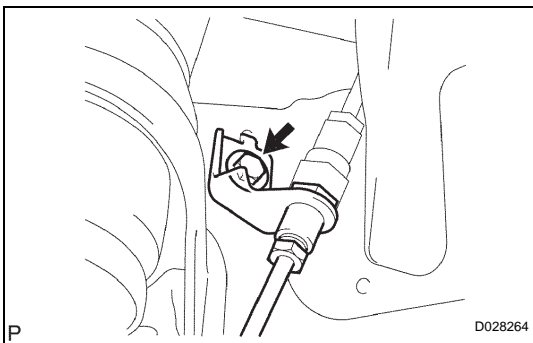
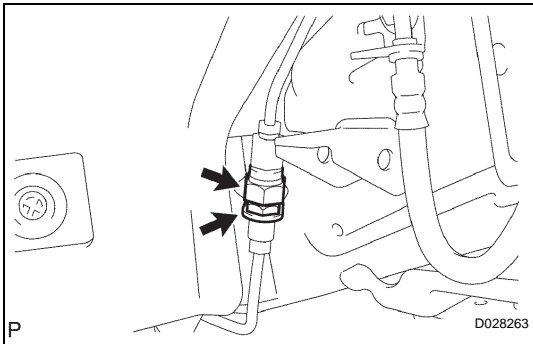

- (b) Remove the bolt and disconnect the bracket.

- (c) Using a spanner to hold the center control absorber assembly, remove the joint.

### NOTICE:

- Do not loosen the flare nut.
- Do not deform or damage the tubes.

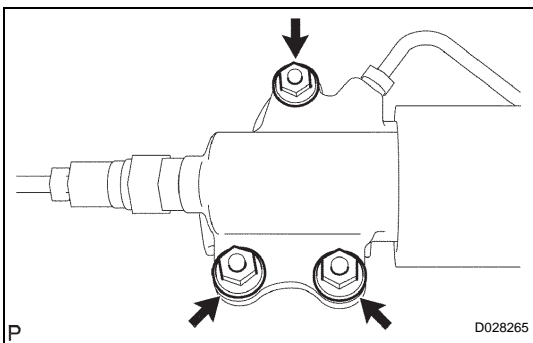

- (d) Remove the 3 nuts and the center control absorber assembly.

### NOTICE:

- Do not deform or damage the tubes.
- Be sure to hold the body part to carry the center control absorber assembly.